



## SAW BANDPASS FILTER

**PART NO.: ACTFH042-2155SA-1109**

<b>Product Type:</b>	<b>Customer:</b>
SAW Single Filter for BAND 66	
	<b>Customer Part NO.:</b>
	<b>Issued Date:</b>

## Features

SAW Single Filter for BAND 66.

- 1 High stability and reliability with good performance.
- 2 Single ended to Single ended.
- 3 Narrow and sharp pass band characteristics. RoHS compatible.
- 4 Low insertion loss and deep stop band attenuation for interference.
- 5 Package size 1.1mm\*0.9mm
- 6 ESD sensitive device.

## Package Dimensions

Ceramic Package: Unit: mm

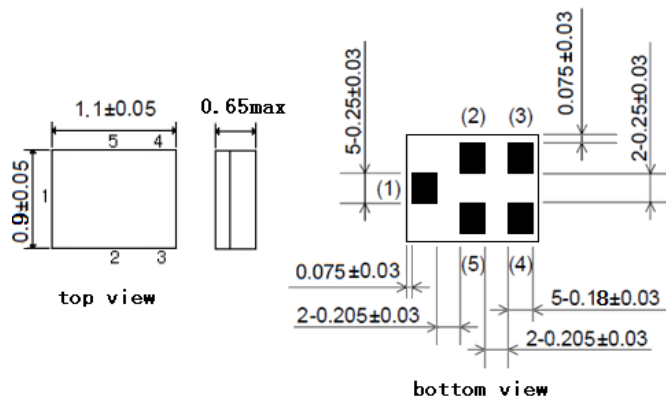

## Pin Configuration

1	Input
4	Output
2,3,5	Ground

## Marking

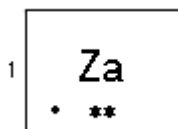

Top View, Laser Marking

"Za" Part number

"." Dot marking, indicates input 1

"1" Terminal1

The first "\*": Month Code (The code shown below varies in a 4-year-cycle)

Month	1	2	3	4	5	6	7	8	9	10	11	12
2016/2020	n	p	q	r	s	t	u	v	w	x	y	z
2017/2021	A	B	C	D	E	F	G	H	J	K	L	M
2018/2022	N	P	Q	R	S	T	U	V	W	X	Y	Z
2019/2023	a	b	c	d	e	f	g	h	i	j	k	m

The second "\*": Date Code

<b>data</b>	□1st	2nd	3rd	4th	5th	6th	7th	8th	9th	10th	
<b>code</b>	A	B	C	D	E	F	G	H	J	K	
<b>data</b>	11th	12th	13th	14th	15th	16th	17th	18th	19th	20th	
<b>code</b>	L	M	N	P	Q	R	S	T	U	V	
<b>data</b>	21st	22nd	23rd	24th	25th	26th	27th	28th	29th	30th	31st
<b>code</b>	W	X	Y	Z	a	b	d	e	f	g	h

### Maximum Ratings

DC Voltage (between any Terminals)	$V_{DC}$	3	V
RF Power (in BW)	$P$	13 dBm /2000hr@55°C	
Operating Temperature Range	$T_A$	-30 ~ +85	°C
Storage Temperature Range	$T_{stg}$	-40 ~ +85	°C
ESD Voltage (HB)	$V_{ESD}$	>150	V
Moisture Sensitivity Levels	$MSL$	2A	

### Electrical Characteristics:

Input impedance:  $Z_{in}=50\ \Omega \parallel 3.4nH$

Output impedance:  $Z_{out}=50\ \Omega \parallel 3.4nH$

Insertion Loss	$IL$				
2110 ... 2200 MHz			2.5	3.5	dB
2110 ... 2170 MHz			2.1	2.6	dB
Passband Ripple	$Pr$				
2110 ... 2200 MHz			1.2	2.5	dB
VSWR	$V_{swr}$				
2110 ... 2200 MHz			1.3	2.0	
Absolute Attenuation	$\alpha$				
10 .... 699 MHz		40	63		dB
699 .... 925 MHz		40	58		dB
1710 .... 1780 MHz		39	44		dB
1730 .... 1920 MHz		37	41		dB
1920 .... 1980 MHz		35	40		dB
2015 .... 2075 MHz		26	33		dB
2285 .... 6130 MHz		24	31		dB
2400 .... 2500 MHz		38	45		dB
4030 .... 4150 MHz		27	33		dB
4220 .... 4340 MHz		27	33		dB
4340 .... 8500 MHz		24	29		dB
Input / Output Impedance (Nominal)		50Ω//3.4nH			

 RoHS Compliant

 Electrostatic Sensitive Device

### Test Circuit

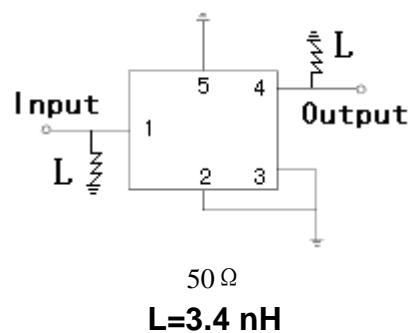

### Typical Frequency Response

S21

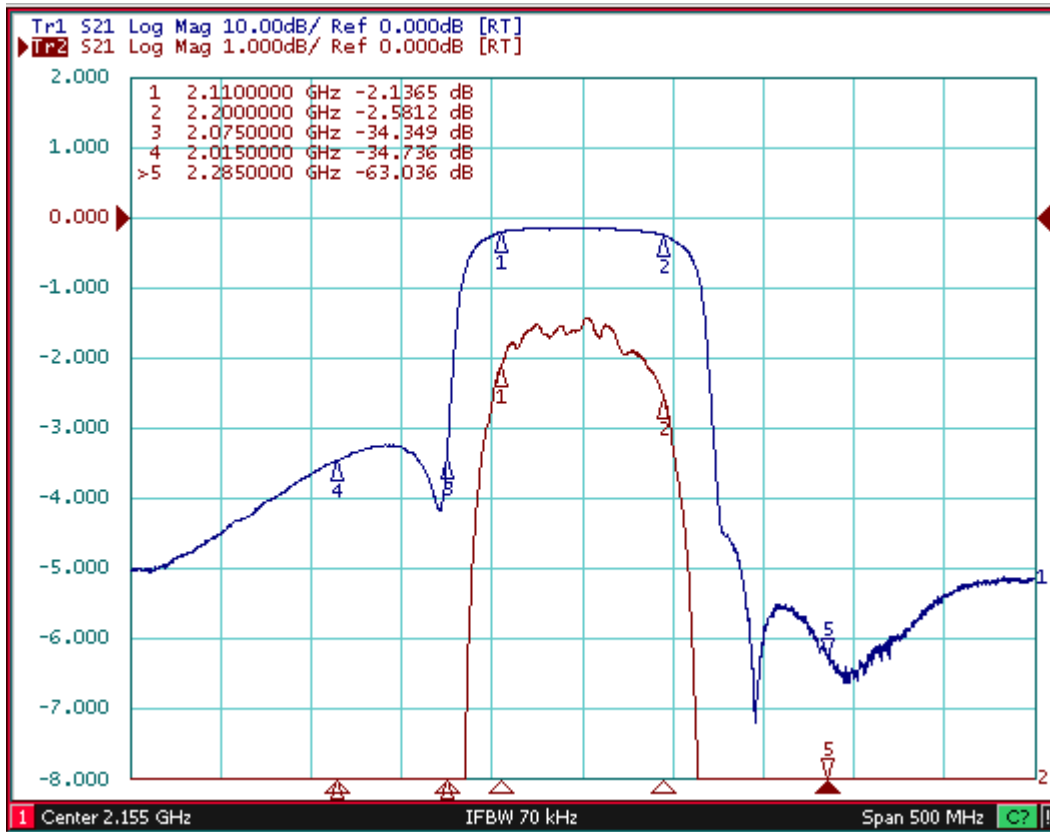

S11 S22

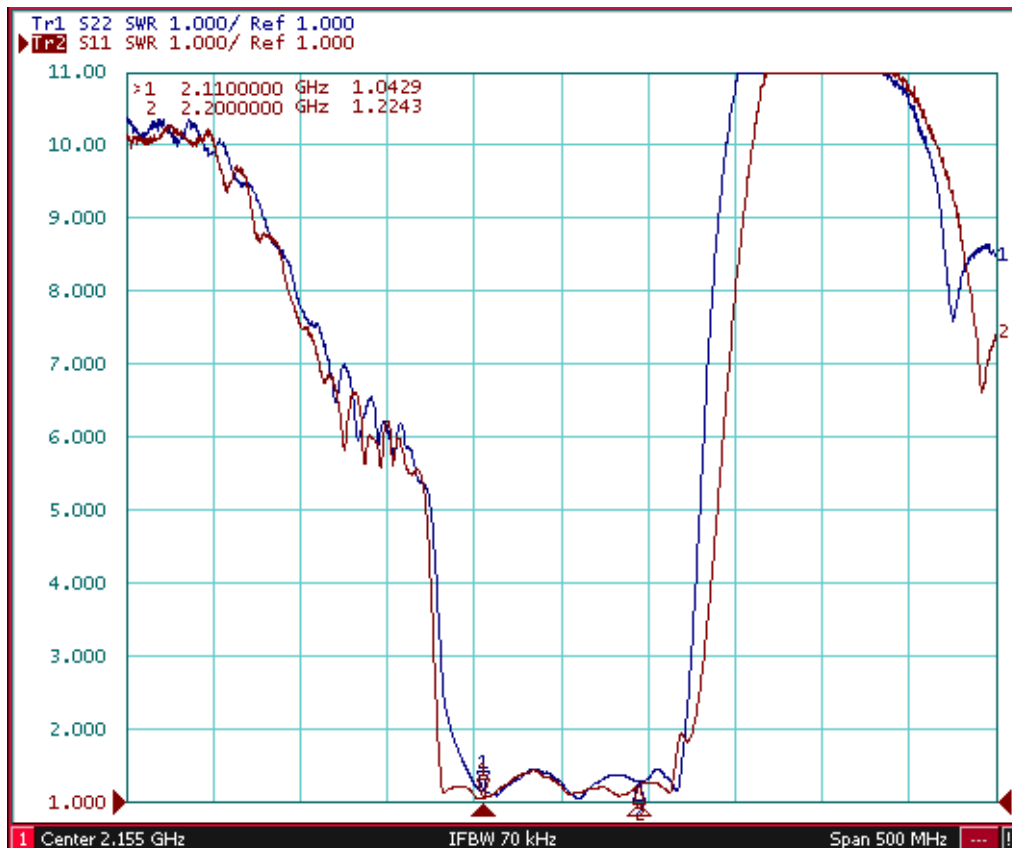

Far side

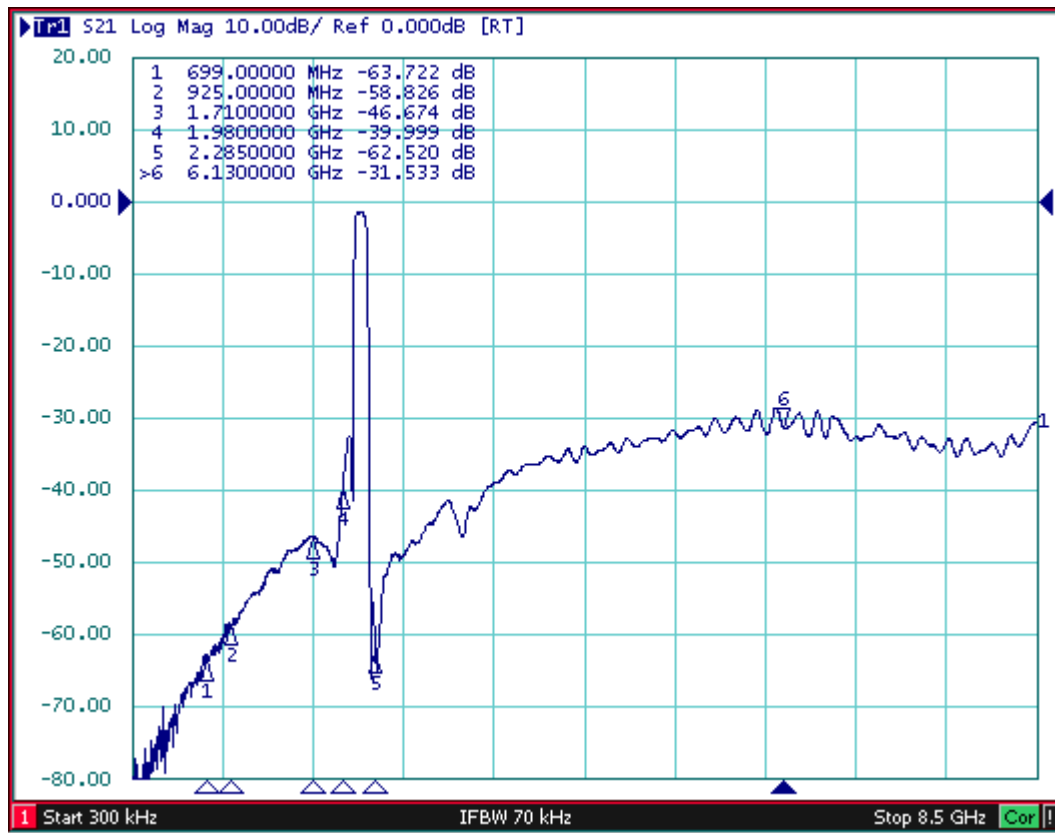



## Stability Characteristics

Item No.	Test Item	STD Reference	Test Conditions	per lot
	Preconditioning	JESD22-A113	1) Temperature Cycling, 5 cycles -40°C to 85°C; 2) Bake, 24 hrs @85±5°C; 3)Moisture Soak, Soak time and conditions per IPC/JEDEC J-STD-020 based on device MSL level; 4) Reflow, 3 reflow cycles; 5) Drying, Room ambient temperature.	All behind
1	Temperature Cycling	JESD22-A104	-40°C / +85°C,5°C/min,15min dwell,<1 min transfer time,500cycles	3*25 pcs
2	High Temperature Storage	JESD22-A103	Temperature=85°C, 1000 hours.	3*25 pcs
3	Temperature Humidity no bias	JEDEC Std A101-B	85°C 85%RH 240 hours	3*25 pcs
4	Human Body Mode ESD	JESD22-A114	Ta=25°C, ≥100V	3 pcs
5	Charge Device Mode ESD	JESD22-C101	Ta=25°C, ≥100V	3 pcs
6	Solderability	JESD22-B102	Wetting: 245°C, 5s.	22 pcs
7	Drop Test	JESD22-B111	1500 Gs, 0.5 millisecond duration, half-sine pulse.	20 pcs
8	Mechanical Shock	JESD-47	Shock pulse of 1500g with pulse duration of 0.5+/-0.1msec (X ,Y & Z); 5 shocks per axis.	3*25 pcs

**Requirements:** The SAW filer shall remain within the electrical specifications after tests.

## Packing Information

### Carrier Tape

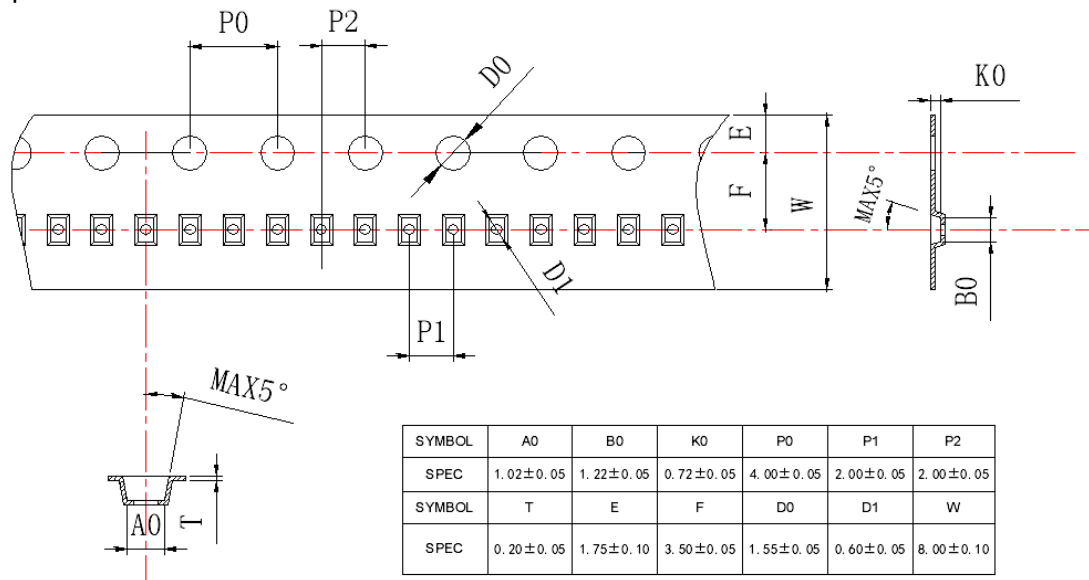

### Reel Dimensions

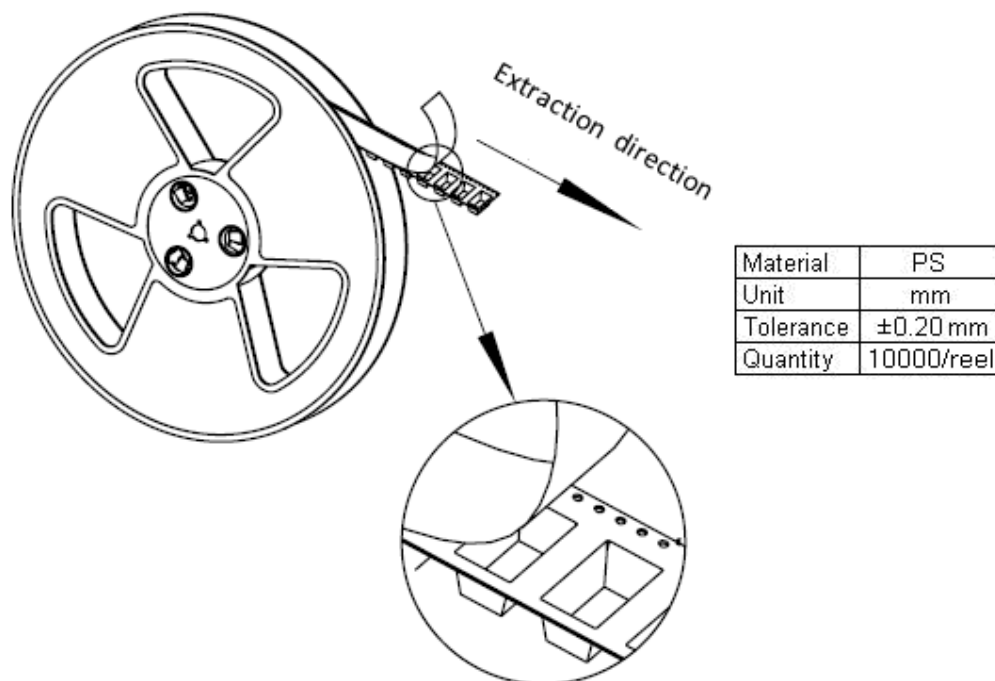

### Outer Packing

Carton Box I	100000	240×210×285	anti-static plastic bag & carton box 1 reel / bag	2.15
Carton Box II	300000	470×310×285	10bags / box (100000 pcs) 30 bags / box (300000pcs)	6.22

Unit: mm

Unit: kg

### Remarks

- SAW devices should not be used in any type of fluid such as water, oil, organic solvent, etc.
- Be certain not to apply voltage exceeding the rated voltage of components.
- Do not operate outside the recommended operating temperature range of components.
- Sudden change of temperature shall be avoided, deterioration of the characteristics can occur.
- Be careful of soldering temperature and duration of components when soldering.
- Do not place soldering iron on the body of components.
- Be careful not to subject the terminals or leads of components to excessive force.
- SAW devices are electrostatic sensitive. Please avoid static voltage during operation and storage.
- Ultrasonic cleaning shall be avoided. Ultrasonic vibration may cause destruction of components.

### Recommended Soldering Profile

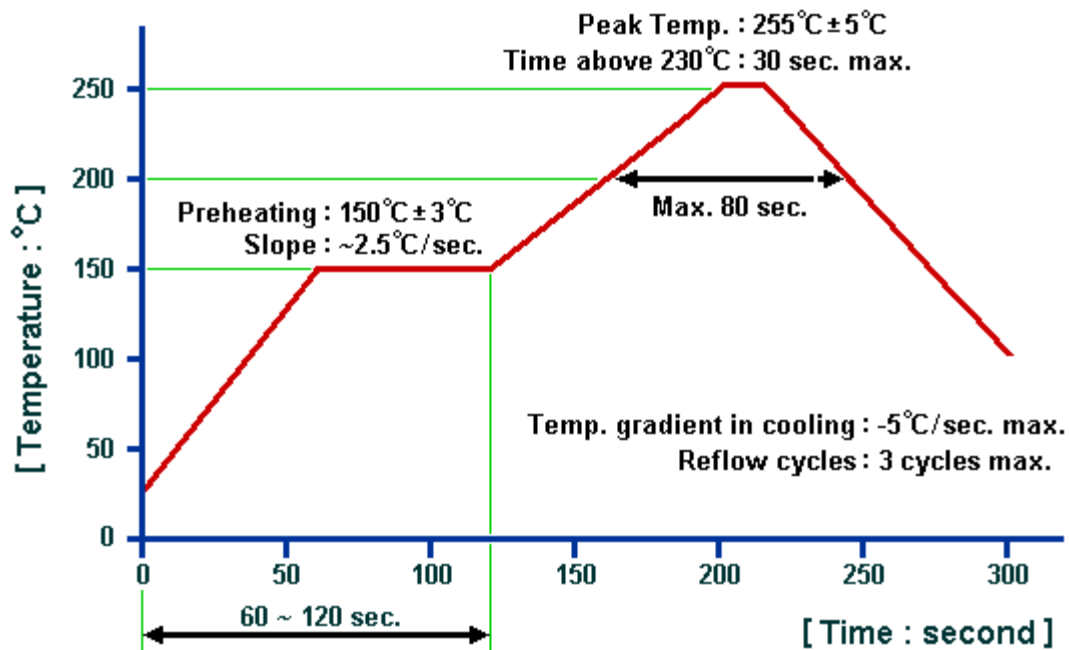

© ACT 2018. All Rights Reserved.

1. The specifications of this device are subject to change or obsolescence without notice.
2. Typically, equipment utilizing this device requires emissions testing and government approval, which is the responsibility of the equipment manufacturer.
3. Our liability is only assumed for the Surface Acoustic Wave (SAW) component(s) per se, not for applications, processes and circuits implemented within components or assemblies.