

# OX1510 Series

OCXO, Sine wave, HCMOS, 27.8 x 27.8 x 15.5mm



- Surface mount package, high stability OCXO
- Unit weight: 20gm max
- RoHS compliant

Output characteristics			
Parameter	Specification		Remarks/Test condition
Frequency range	5.0MHz ~ 40.0MHz		HCMOS output Standard: 10MHz, 12.8MHz, 20MHz, 40MHz
Frequency range	5.0MHz ~ 150.0MHz		Sinewave output Standard: 10MHz, 100MHz, 125MHz
Supply voltage (Vs)	3.3V typical (HCMOS)		Min: 3.15V, Max: 3.45V
	5.0V typical (HCMOS, Sinewave)		Min: 4.75V, Max: 5.25V
	12.0V typical (Sinewave)		Min: 11.4V, Max: 12.6V
Reference voltage VREF output	3.0V		For Vs = 3.3V
	4.0V		For Vs = 5.0V
	5.0V		For Vs = 12.0V, For f≤40MHz
	10.0V		For Vs = 12.0V, For f>40MHz
Warm-up current consumption	900.0mA max		Vs = 3.3V
	600.0mA max		Vs = 5.0V
	350.0mA max		Vs = 12.0V
Steady state current consumption @25°C	350.0mA max		Vs = 3.3V
	250.0mA max		Vs = 5.0V
	150.0mA max		Vs = 12.0V
RF output			
Output waveform	Sine wave	HCMOS	
Output load	50.0Ω	15.0pF	±10%
Output level	Min: +7.0dBm	-	
Harmonics	-30.0dBc max	-	
Spurious	-90.0dBc max	-	
Duty cycle	-	40%/60% <sup>1</sup>	@ Vs/2
Rise/Fall time	-	5.0ns	@ 10% ~ 90% Vs
Warm-up time at +25°C	3.0 minute typical, 5.0 minute max		Δf final/ fnominal < ±0.1ppm
Phase noise	Contact factory		
Frequency stability (Typical, @ 10.00MHz)			
Initial tolerance	±300.0ppb max		At +25°C, Vc @ centre value
vs Operating temperature range	±5.0ppb ~ ±200.0ppb		Table 1
vs Supply voltage variation	±10.0ppb max		Vs ± 5%
vs Load change	±5.0ppb max		RL ± 10%
Long term aging/day	AT-cut: ±10.0ppb max    SC-cut: ±2.0ppb max		After 30 days operation
Long term aging 1 <sup>st</sup> year	AT-cut: 300.0ppb typical, ±500.0ppb max SC-cut: 50.0ppb typical, ±200.0ppb max		After 30 days operation
Frequency adjustment range			
Electronic frequency control (EFC)	AT-cut: ±2.0ppm min, ±5.0ppm max SC-cut: ±0.8ppm min		
EFC voltage Vc	Vref/2 ± Vref/2		
EFC slope	Positive		
EFC input impedance	100.0kΩ min		
Absolute maximum ratings			
Supply voltage Vs	Min: -0.5V	Max: Vs + 10%	Vs to GND
Control voltage Vc	Min: -0.5V	15V	Vc to GND
Storage temperature	-55°C ~ +125°C		

# OX1510 Series

OCXO, Sine wave, HCMOS, 27.8 x 27.8 x 15.5mm



Table 2: Frequency stability vs operating temperature range

Temperature (°C)	±5.0ppb	±10.0ppb	±25.0ppb	±50.0ppb	±100.0ppb	±200.0ppb
0°C ~ +50	SC-cut v	SC-cut v	SC-cut v	AT-cut v	AT-cut v	AT-cut v
-10°C ~ +60	SC-cut v	SC-cut v	SC-cut v	AT-cut v	AT-cut v	AT-cut v
-20°C ~ +70	SC-cut v	SC-cut v	SC-cut v	SC-cut v	AT-cut v	AT-cut v
-30°C ~ +70	Enquire	SC-cut v	SC-cut v	SC-cut v	SC-cut v	AT-cut v
-40°C ~ +75	Enquire	Enquire	SC-cut v	SC-cut v	SC-cut v	SC-cut v
-40°C ~ +85	Enquire	Enquire	SC-cut v	SC-cut v	SC-cut v	SC-cut v
-55°C ~ +85	X	Enquire	Enquire	SC-cut v	SC-cut v	SC-cut v

## Mechanical dimensions and Pin functions

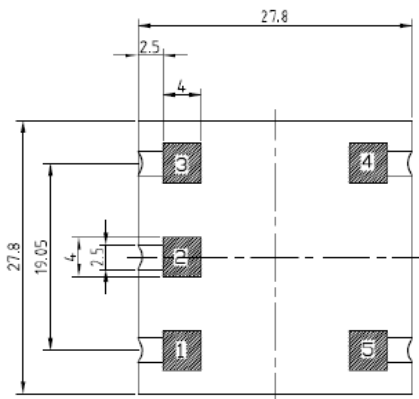

no pcbtrack beneath this area

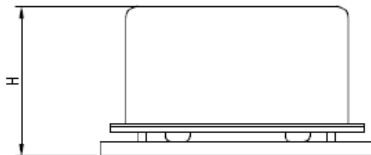

## Pin connections

Pin #	Symbol	Function
1	RF OUT	RF Output
2	GND	Ground
3	V <sub>C</sub>	Control Voltage (EFC)
4	VREF	Reference voltage
5	V <sub>S</sub>	Supply Voltage

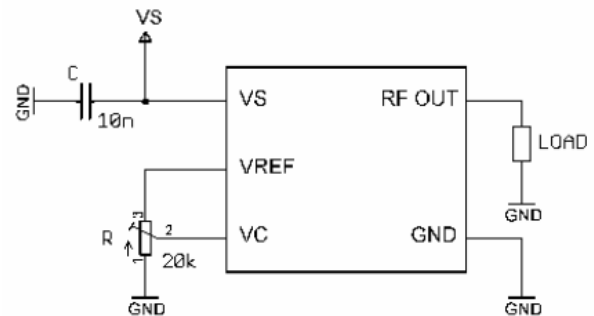

## ACT part number

ACT will provide a unique part number with full specification based on your requirements, please provide the following details.

ACT series	Frequency (MHz)	Supply voltage (V)	Output type	Frequency stability (ppb)	Operating temperature range (°C)
OX1510					

# OX1510 Series

OCXO, Sine wave, HCMOS, 27.8 x 27.8 x 15.5mm



Table 3: Environmental conditions

Test	IEC60068 part...	IEC 60679-1 Clause	MIL-STD-202G Method	MIL-PRF-810F Method	MIL-PRF-55310D Clause	Test conditions (IEC)
Sealing tests (if applicable)	2-17	5.6	112E		3.6	Gross leak: Test QC, Fine leak : Test QK
Solderability resistance to soldering heat	2-20 2-58	5.6	208H 210F		3.6.52 3.6.48	Test Ta Method 1 Test Td1 Method 2 Test Td2 Method 2
Shock	2-27	5.6.8	213B	516.4	3.6	Test Ea, 3 x per axes 100g, 6 ms half sine pulse
Vibration, sinusoidal	2-6	5.6.7.1	201A 204D	516.4-4	3.6.38.1 3.6.38.2	Test Fc, 30 min per axes, 10Hz - 55Hz 0, 75mm; 55Hz-2kHz, 10g
Vibration, random	2-64	5.6.7.3	214A	514.5	3.6.38.3 3.6.38.4	Test Fdb
Endurance Tests -Ageing - extended aging		5.7.1 5.7.2	108A		4.8	30 days @ 85°C, OCXO @ 25°C 1000h, 2000h, 8000h @ 85°C

Drawing control: (Internal use only)  
Issue number: 1  
Date: 01/06/2017  
Internal reference: O1