

# (V)TCT75-4 Series (MHz)

TCXO/VC-TCXO, 7.0 x 5.0mm, HCMOS/TTL

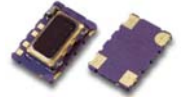

REACH and RoHS compliant  
MHz range frequency  
From  $\pm 0.5$ ppm stability over 0°C ~ +50°C



Parameters		Specification		Remarks
Frequency range	F_nom	1.25MHz ~ 40.0MHz		
Supply voltage	Vcc	2.5V, 3.0V, 3.3V, 5.0V		
Initial frequency tolerance	F_tol	$\pm 2.0$ ppm		At +25°C $\pm 2$ °C
Frequency stability	vs Temperature	F_stb	$\pm 0.5$ ppm ~ $\pm 3.0$ ppm	Table 1
	vs Load	F_load	$\pm 0.3$ ppm max	$\pm 10\%$ load condition change
	vs Voltage	F_Vcc	$\pm 0.3$ ppm max	$\pm 5\%$ input voltage change
	vs Aging	F_age	$\pm 1.0$ ppm/year max	At +25°C
	vs Reflow		$\pm 1.0$ ppm/year max	1 reflow and measured after 24hrs
Operating temperature range (°C)	Topr	0°C ~ +50°C to -40°C ~ +85°C		Table 1
Storage temperature (°C)	Tstg	-55°C ~ +125°C		
Output waveform		HCMOS/TTL		
Output voltage high	Voh	90% Vcc min		
Output voltage low	Vol	10% Vcc max		
Output load		15pF		
Current consumption	Icc	10mA (2.5V), 13mA(3.0V, 3.3V), 27mA(5.0V)		Max Over operating temperature range
Rise and fall time	Tr, Tf	10ns max		20% to 80% of waveform
Duty cycle	SYM	45%/55%, 40%/60%		Measured at 50% Vcc
Start-up time	T_str	5.0m sec (typical), 10.0m sec. (Max)		Reach 90% amplitude at +25°C $\pm 2$ °C
<b>VC-TCXO option only</b>				
Control voltage	Vc	1.5V $\pm$ 1.0V		For all supply voltages
Frequency tuning (ppm)		$\pm 5.0$ ppm min		
Linearity/Slope polarity		$\pm 10.0\%$ max/Positive slope		Positive voltage for positive frequency shift
Input impedance		50.0M $\Omega$ min		
Modulation bandwidth		20.0kHz min		

Table 1. Frequency Stability vs Temperature

Temp. (°C)	Stability in ppm					
	$\pm 0.5$	$\pm 1.0$	$\pm 1.5$	$\pm 2.0$	$\pm 2.5$	$\pm 3.0$
0°C to 50°C	✓	✓	✓	✓	✓	✓
-10°C to 60°C	Enq.	✓	✓	✓	✓	✓
-20°C to 70°C	X	✓	✓	✓	✓	✓
-30°C to 75°C	X	✓	✓	✓	✓	✓
-30°C to 85°C	X	✓	✓	✓	✓	✓
-40°C to 85°C	X	Enq.	✓	✓	✓	✓

Dimensions (Unit:mm)

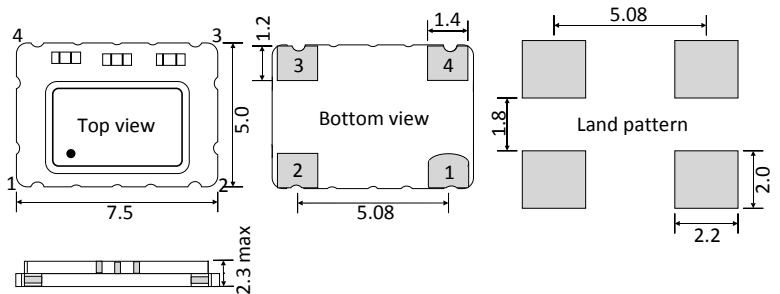

Phase Noise (10.0MHz example)	dBc/Hz typical
10Hz	-96
100Hz	-122
1kHz	-138
10kHz	-145
100kHz	-150

- Pad 1 : Control voltage (VCTCXO). No connection(TCXO)
- Pad 2 : Ground
- Pad 3 : Output
- Pad 4 : Supply Voltage

# (V)TCT75-4 Series (MHz)

TCXO/VC-TCXO, 7.0 x 5.0mm, HCMOS/TTL



TCXO part number generation											
TT75	2600	M	B	X	N	E	N	X	X	L	-PF
ACT series Code	Frequency (MHz) Ex. 26.00MHz	Temp. stability (±ppm)	Supply voltage (V)	Operating temp. range (°C)	Frequency tuning (±ppm)	Output wave	Mechanical tuning (±ppm)	Polarity	Duty cycle (%/%)	Tape & Reel	RoHS
TT75	26MHz = 2600 8MHz = 0800  < 100MHz First 4 digit of frequency  > 100MHz First 5 digit of frequency	0.5 = R 1.0 = P 1.5 = O 2.0 = N 2.5 = M 3.0 = L	2.5V = C 3.0V = E 3.3V = B 5.0V = A	0 ~ 50 = D -10 ~ +60 = F -20 ~ +70 = B -30 ~ +75 = W -30 ~ +85 = X -40 ~ +85 = K	None = N	HCMOS = E HCMOS/TTL = J	None = X	None = X	40/60 = S 45/55 = H	Loose = L 1000 = C 2000 = E	-PF
<p>Note: It is important to suffix the above part number with full frequency required to give a completed part number as illustrated below.                      Full Example Part Number : <b>TT752600MBXNEXHL-PF [26MHz]</b>, <b>TT751474MBXNEXHL-PF-PF [14.7456MHz]</b></p>											

VC-TCXO part number generation													
VTT75	1474	M	B	X	N	B	X	D	P	E	Z	L	-PF
ACT series Code	Frequency (MHz) Ex. 14.7456MHz	Temp. stability (±ppm)	Supply voltage (V)	Operating temp. range (°C)	Frequency tuning (±ppm)	Output wave	Mechanical tuning (±ppm)	Electrical tuning (±ppm)	Polarity	Linearity	Duty cycle (%/%)	Tape & Reel	RoHS code
VTT75	< 100MHz First 4 digit of frequency  > 100MHz First 5 digit of frequency	0.5 = R 1.0 = P 1.5 = O 2.0 = N 2.5 = M 3.0 = L	2.5V = C 3.0V = E 3.3V = B 5.0V = A	0 ~ 50 = D -10 ~ +60 = F -20 ~ +70 = B -30 ~ +75 = W -30 ~ +85 = X -40 ~ +85 = K	Voltage Control Only = E	HCMOS = E HCMOS/TTL = J	None = X	±5.0 = D	Positive = P	±10% = E	40/60 = S 45/55 = H	Loose = L 1000 = C 2000 = D	-PF
<p>Note: It is important to suffix the above part number with full frequency required to give a completed part number as illustrated below.                      Full Example Part Number : <b>VTT751474MBXEEXDPEHL-PF (14.7456MHz)</b></p>													

# (V)TCT75-4 Series (MHz)

TCXO/VC-TCXO, 7.0 x 5.0mm, HCMOS/TTL



Test circuit

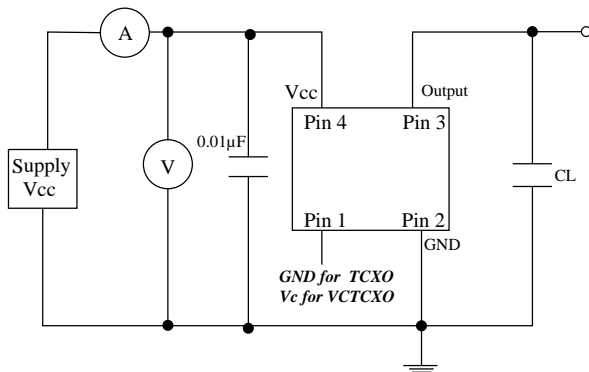

Test waveform

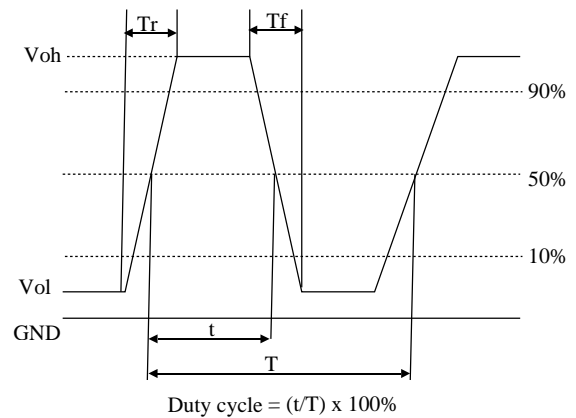

Solder reflow profile

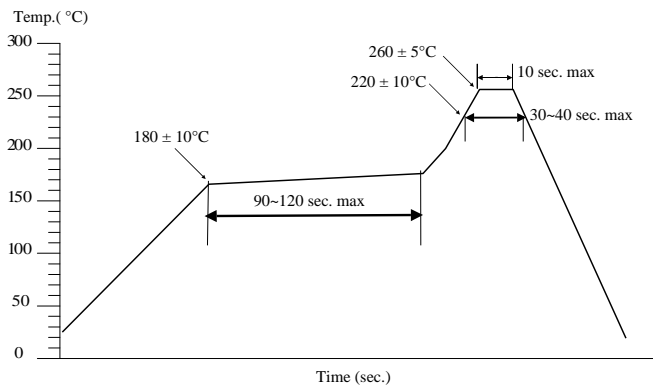

Drawing control: (Internal use only)  
 Commodity code: 854370 90 99  
 Issue number : N1  
 Date : 02/01/2017  
 Internal reference : M6