

CM53LJD Series

VCXO, 5.0 x 3.2mm, LVPECL, LVDS Output

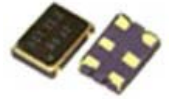

REACH and RoHS compliant
 Recommended for non-standard frequency or frequency > 50MHz
 Typical jitter 0.6ps



Parameters	Specification		Remarks
Frequency range	F_nom	10.0MHz ~ 1450.0MHz	
Supply voltage	Vcc	2.5V±5% , 3.3V±5%	
Frequency stability	F_stb	±25.0ppm, ±50.0ppm, ±100.0ppm	Includes initial tolerance, stability over temperature, load, Vcc
Aging	F_age	±2.0ppm max first year at 25°C	±10.0ppm max over 10 years
Operating temperature range (°C)	Topr	-10°C ~ +70°C, -40°C ~ +85°C	
Storage temperature (°C)	Tstg	-55°C ~ +125°C	
Output waveform		LVPECL, LVDS	
Output load		Differential	
Output voltage high	Voh	LVPECL: Vcc - 1.03 (min), Vcc - 0.6 (max)	LVDS: 1.4V typical, 1.6V max
Output voltage low	Vol	LVPECL: Vcc - 1.85 (min), Vcc - 1.6 (max)	LVDS: 1.1V typical, 0.9V min
Rise time	Tr	0.5nsec max, 0.2nsec typical	Measured over 20% to 80% of waveform
Fall time	Tf	0.5nsec max, 0.2nsec typical	
Duty cycle		45%/55%	Measured at 50% of waveform
Current consumption	Icc	Table 1	
Start-up time	T_str	10.0msec max	
Phase jitter (RMS)		0.6psec typical (12kHz to 20MHz)	<100fsec for 1.875kHz to 20MHz
Phase noise		Table 2	
Frequency pulling	F_pull	2.5V : ±90.0ppm min, 3.3V : ±100.0ppm min	Up to ±200.0ppm min is available
Control voltage	Vc	2.5V: 1.25V ± 1.05V, 3.3V: 1.65V ± 1.35V	
Slope / Linearity		Positive / ±10% max, ±5% typical	
Modulation bandwidth		10kHz min	Measured at -3dB
Input impedance		1MΩ typical	
Moisture sensitive level / ESD sensitive device	MSL	1 / Yes	
Tri-state		Enable high, No connection or 0.7% of Vcc min is applied to Tri-state pin to Enable output. 0.3% of Vcc max to disable output (high impedance).	
Output enable time / Disable time		200nsec max / 50 nsec max	

Output	LVPECL		LVDS	
	2.5V	3.3V	2.5V	3.3V
100MHz	46mA	50mA	16mA	25mA
250MHz	48mA	55mA	18mA	30mA
500MHz	53mA	60mA	21mA	35mA
750MHz	56mA	64mA	22mA	39mA
1.0GHz	60mA	68mA	24mA	43mA
1.35GHz	65mA	72mA	26mA	47mA

Note: All values are typical over operating temperature range. Current without output is 16mA typical.

Dimensions(Unit:mm)

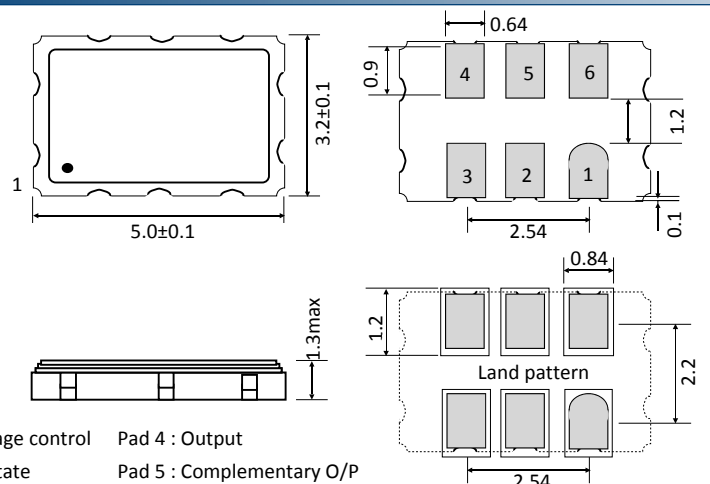

- Pad 1 : Voltage control
- Pad 2 : Tri-state
- Pad 3 : Ground
- Pad 4 : Output
- Pad 5 : Complementary O/P
- Pad 6 : Suppl voltage

CM53LJD Series

VCXO, 5.0 x 3.2mm, LVPECL, LVDS Output



Table 2. SSB Phase noise [dBc/Hz (typical)]

Offset	77.76MHz	122.88MHz	125MHz	156.25MHz	212.5MHz	491.52MHz	622.08MHz	1000MHz	1250MHz
10 Hz	-74	-68	-69	-67	-53	-56	-51	-46	-32
100 Hz	-104	-98	-92	-92	-86	-87	-77	-80	-68
1 kHz	-121	-114	-112	-112	-109	-101	-99	-96	-94
10 kHz	-130	-123	-121	-121	-118	-110	-109	-105	-103
100 kHz	-134	-127	-124	-124	-121	-113	-114	-108	-105
1 MHz	-140	-138	-136	-136	-133	-125	-121	-116	-117
10 MHz	-157	-155	-153	-153	-151	-143	-141	-135	-136

Part number generation

V53	2600	B	B	I	E	E	J	P	H	N	L	-PF
ACT series Code	Frequency (MHz)	Frequency Stability all causes (\pm ppm)	Supply voltage (Vcc)	Operating temp. range ($^{\circ}$ C)	Linearity (\pm %)	Output wave	Minimum pulling (\pm ppm)	Polarity	Duty cycle (%/%)	Tristate	Tape & Reel	RoHS Code
V53	26MHz = 2600 (Note 1)	25 = C 50 = B 100 = A	2.5 = C 3.3 = B	-10 \sim +70 = C -20 \sim +70 = B -40 \sim +85 = I	10 = E	LVPECL = L LVDS = K	\pm 90 = K \pm 100 = B \pm 150 = C \pm 200 = D	Positive = P	45/55 = H	Yes = P No = N	Loose = L 1000 = C	-PF

Note 1 : Frequency < 100MHz use first 4 digit of frequency in part numbering, Frequency > 100MHz use first 5 digit of frequency. Example: 26.00MHz = 2600, 8.00MHz = 0800, 14.7456MHz = 1474, 100MHz = 10000 .It is important to suffix the above part number with full frequency required to give a completed part number as illustrated below.

Full Example part number : V53-2600BBIELKPHNL-PF [26MHz], V53-1474BBIEKKPHNL-PF [14.7456MHz]

LVPECL test circuit

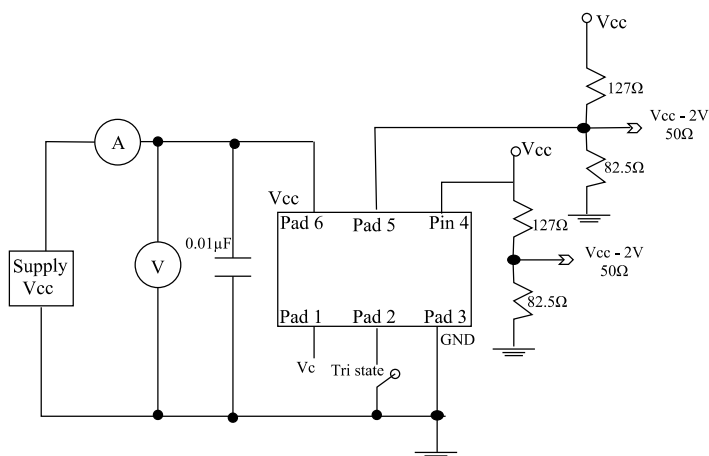

LVPECL Resistor values

Vcc	R1, R3	R2, R4
+3.3V	127 Ω	82.5 Ω
+2.5V	250 Ω	62.5 Ω

Waveform

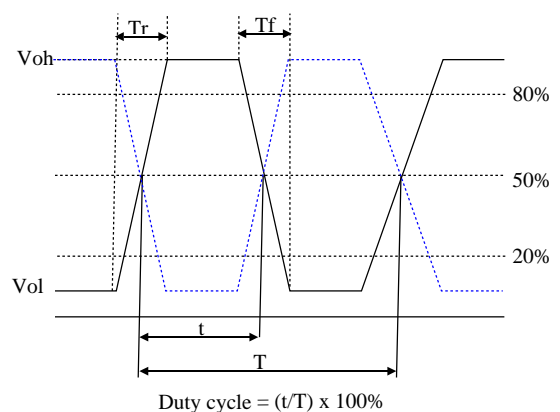

CM53LJD Series

VCXO, 5.0 x 3.2mm, LVPECL, LVDS Output



LVDS Test circuit

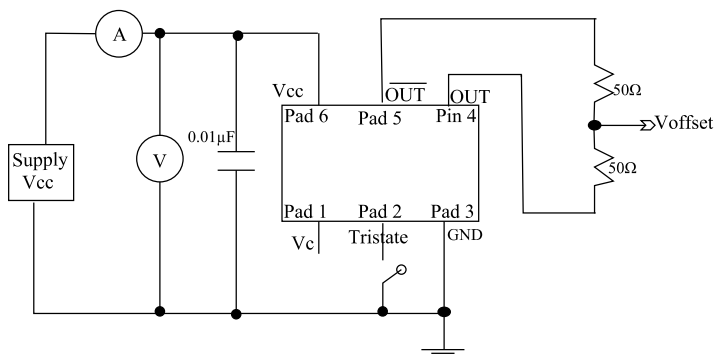

Test waveform

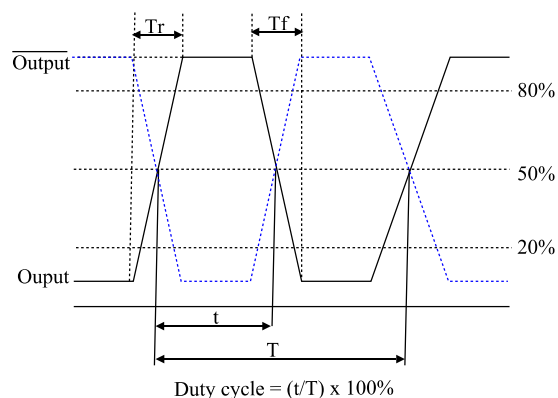

Solder reflow profile

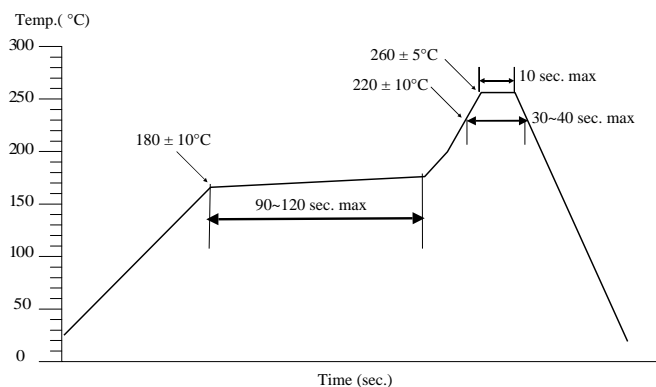

Drawing control: (Internal use only)
 Commodity code: 844370 90 99
 Issue number : N1
 Date : 01/02/2017
 Internal reference : M6