

3CSV-6 Series

VCXO, 3.2 x 2.5mm, HCMOS/TTL



REACH and RoHS compliant
Tristate function



Parameters	Specification		Remarks
Frequency range	F_nom	1.0MHz ~ 50.0MHz	Fundamental
Supply voltage	Vcc	1.8V±5%, 2.5V±5%, 3.3V±5%, 5.0V±10%	
Frequency stability	F_stb	±25.0ppm, ±50.0ppm, ±100.0ppm	Includes initial tolerance, stability over temperature, load, Vcc, aging, shock and vibration
Aging	F_age	±3.0ppm/year max	
Operating temperature range (°C)	Topr	-10°C ~ +70°C, -40°C ~ +85°C	
Storage temperature (°C)	Tstg	-55°C ~ +125°C	
Output waveform		HCMOS/TTL	
Output load		15pF max HCMOS 2 TTL gates	
Output voltage high	Voh	HCMOS: 90% of Vcc min TTL: 2.4V min	
Output voltage low	Vol	HCMOS: 10% of Vcc max TTL: 0.4V max	
Rise time	Tr	6.0nsec max, 4nsec typical	Measured over 20% to 80% of waveform
Fall time	Tf	6.0nsec max, 4nsec typical	
Duty cycle		45%/55%, 40%/60%	Measured at 50% of waveform
Current consumption	Icc	10.0 ~ 45.0mA - Frequency dependant	For 27MHz: Typical 10mA at 3.3V, 20mA at 5.0V
Start-up time	T_str	10.0msec max, 5.0msec typical	
Phase jitter (RMS)		1psec max	12kHz to 20MHz integrated
Phase noise		Table 1	
Frequency pulling	F_pull	±80.0ppm min ,	Over Vc range
Control voltage	Vc	1.8V: 0.9V ± 0.9V 2.5V: 1.25V ± 1.0V 3.3V: 1.65V ± 1.35V 5.0V: 2.5V ± 2.0V	
Slope / Linearity		Positive / 10% max, 6% typical	
Modulation bandwidth		10kHz min	Measured at -3dB with Vc at 1.65V or at 2.5V
Input impedance		1MΩ typical	
Moisture sensitive level / ESD sensitive device	MSL	1 / Yes	
Tri-state		Enable high, No connection or Vcc - 0.5V min is applied to Tri-state pin to Enable output	
		Ground + 0.5V max to disable output (high impedance)	

10 Hz	-40dBc/Hz
100 Hz	-104dBc/Hz
1k Hz	-132dBc/Hz
10k Hz	-147dBc/Hz
100k Hz	-152dBc/Hz
1M Hz	-150dBc/Hz

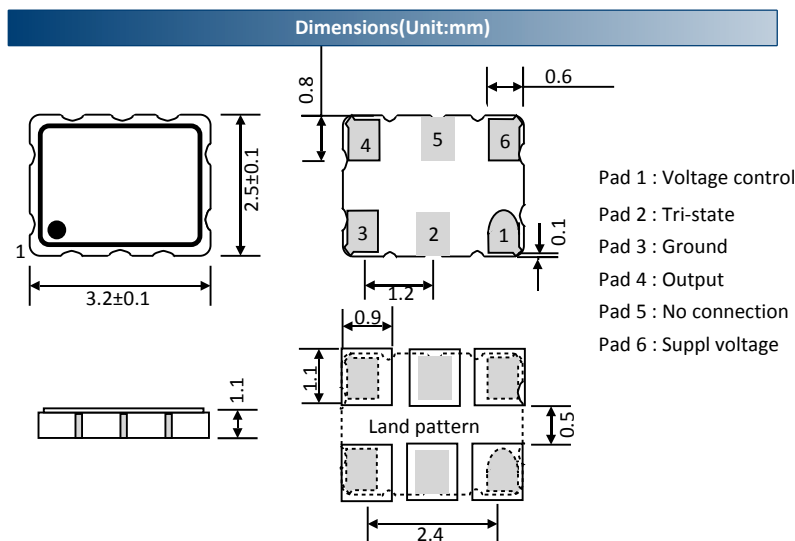

3CSV-6 Series

VCXO, 3.2 x 2.5mm, HCMOS/TTL



Part number generation												
V366	2600	B	B	I	E	E	J	P	H	N	L	-PF
ACT series Code	Frequency (MHz)	Frequency Stability all causes (\pm ppm)	Supply voltage (Vcc)	Operating temp. range ($^{\circ}$ C)	Linearity (\pm %)	Output wave	Minimum pulling (\pm ppm)	Polarity	Duty cycle (%/%)	Tristate	Tape & Reel	RoHS Code
V366	26MHz = 2600 (Note 1)	25 = C 50 = B 100 = A	1.8 = D 2.5 = C 3.3 = B 5.0 = A	-10~+70 = C -20~+70 = B -40~+85 = I	10 = E	HCMOS = E TTL = H	\pm 80 = J	Positive = P	40/60 = S 45/55 = H	Yes = P No = N	Loose = L 1000 = C	-PF

Note 1 : Frequency < 100MHz use first 4 digit of frequency in part numbering, Frequency > 100MHz use first 5 digit of frequency. Example: 26.00MHz = 2600, 8.00MHz = 0800, 14.7456MHz = 1474, 100MHz = 10000 .It is important to suffix the above part number with full frequency required to give a completed part number as illustrated below.
Full Example part number : **V366-2600BBIEEJPHNL-PF [26MHz]**, **V366-1474BBIEEJPHNL-PF [14.7456MHz]**

HCMOS test circuit

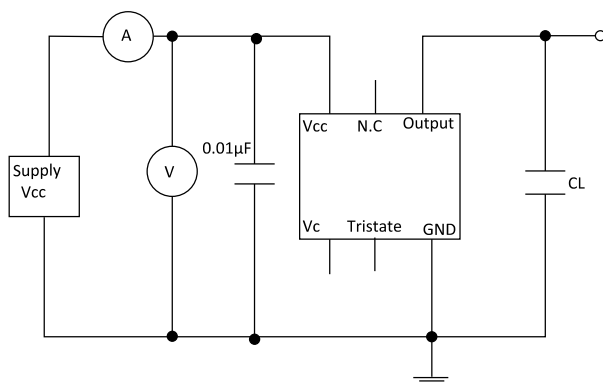

Waveform

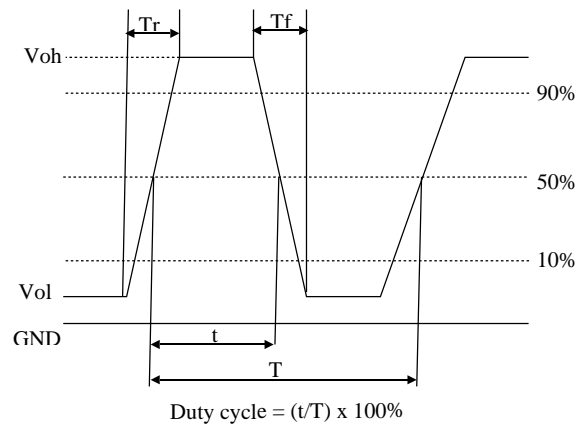

Solder reflow profile

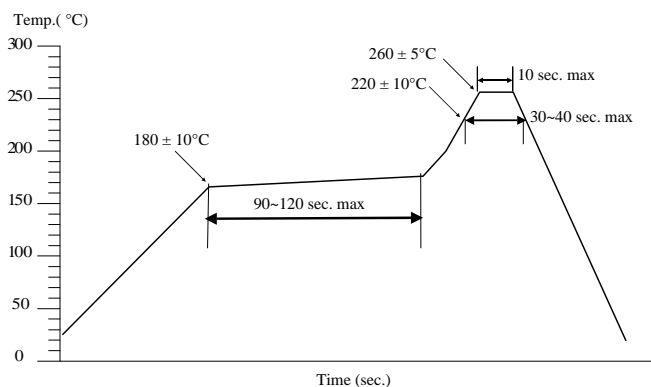

Drawing control: (Internal use only)
Commodity code: 844370 90 99
Issue number : N1
Date : 01/02/2017
Internal reference : M6